

An Analysis of Women's Rowing and Sculling Technique

Author: Penny Chuter (GBR)

1.0 Introduction

1.1 Perspective on Technique

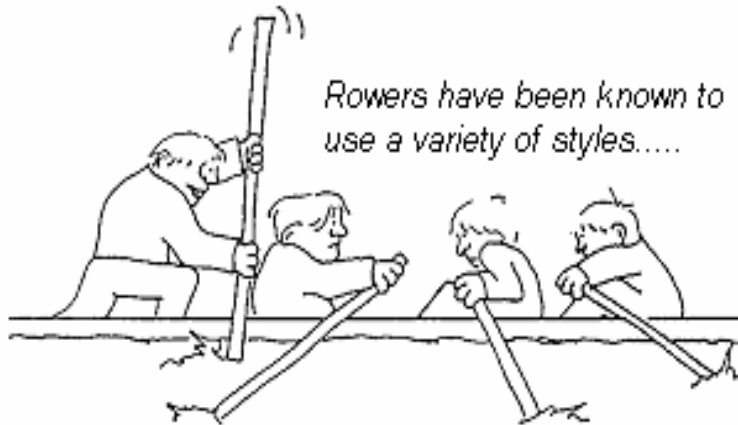

Fig. 1

Karl Adam quote: "Training and physiology will give you lengths, whereas good technique will only give you metres."

However, technical efficiency is more important for those with limited physique and physiology. When races are now won and lost by fractions of a second, technique can make the difference between gold and silver.

1.2 Technique Variations for Women

The range on technique variation for women in general does not fall outside the normal range of variability within the sport as a whole.

The fundamental principles are the same, but coaches should adapt techniques to suit the specifics of the individual in terms of height, weight, power and flexibility. If it is assumed that women, on the whole, are shorter and weaker, and more flexible than men, then it can be assumed that women's technique will tend to accommodate these facts.

My basic contention is that women (in general) should row longer than men for the following reasons:

1. If weaker - women need more time during the stroke to develop power.
2. If shorter - women need larger arcs.
3. If less experienced - all rowers achieve less than their full length potential.

In addition, in general, coaches should allow for the facts that:

As the stroke rate increases from winter to summer, there is a tendency for stroke length to shorten.

As a race progresses from start to finish, fatigue also causes a tendency for the stroke length to shorten.

Overall length of stroke is the most important basic principle of boat propulsion. The force of the stroke and the number of strokes per minute are the other two factors. For women (where less strength may be a factor) length of stroke is even more important.

At national and international level, however, my main observation of women's crews in general is that they row too short. The most obvious exception is the women of the former German Democratic Republic, who set an example for all to copy and show clearly that with the right rigging and good technical coaching of the reach forward women can row long.

However, it should be borne in mind that many women competing at international level are not necessarily shorter or weaker than men. Table 1 shows that the average height and weight of the GDR women's team at the 1988 Seoul Olympic Games was 1.83 m (6'0") and 77.6 kg (12 st 3 lb or 171 lbs).

Table 1: Average Heights and Weights of 1988 GDR Women's Olympic Team

Height		Weight	
Tallest	1.88 m (6'2")	Heaviest	84 kg (13 st 3 lbs or 185 lbs)
Shortest	1.77 m (5'10")	Lightest	68 kg (10 st 10 lbs or 150 lbs)
Average	1.827 m (6'0")	Average	77.6 kg (12 st 3 lbs or 171 lbs)

Table 2: Height and Weight Data for World Championship Medallists - Lightweight Women

Height (minimum)	Approx. 1.67 m (5'6")
Weight	Approx. 58 kg (9 st 0 lbs or 128 lbs)

Table 3: Single Scull Time Differences

Athlete Comparisons	Time Difference
Women vs. Men	Approx. 40 seconds slower
Lightweight Women vs. Heavyweight Women	Approx. 15 seconds slower
Lightweight Women vs. Men	Approx. 55 seconds slower

Beyond rowing larger arcs in the water, I have no recommendation for adaptation of technique especially for women. Adaptations should be specific to the individual or crew.

1.3 Technical Developments - 1976-1990

1. Compressed and Orthodox Techniques

The greatest variation between national techniques worldwide reached its peak at the 1976 Olympic Games in Montreal. There we saw the extreme of what has become known as the Karl Adam "compressed" Technique shown by GBR and FRG crews especially. At the other extreme we saw the orthodox English technique displayed by GDR.

By 1984 those nations using the compressed technique had come full circle and the technique variance between the different nations is now only one of slight differences of emphasis based on the orthodox GDR technique.

2. Rigger Heights

Since 1976 riggers have gradually become higher. The reasons will be mentioned later.

3. Rigger Spreads

Since the 1960s, rigger spreads first moved towards larger spreads (smaller stroke arcs). This trend also reached its peak around 1976. Since then, and particularly since 1984, spreads have become smaller (larger stroke arcs) again, although not a reversion to the pre-1960s situation. The rationale for these trends will also be discussed later.

4. Women's Distance - 2000m

After the 1984 Olympic Games, the distance for women was extended to 2000m. This put a greater emphasis upon endurance and a lesser emphasis on "brute" strength, which has led to a change in women's physiques and in their technique.

There is now much less emphasis on an exaggerated "lie back" at the finish in order to use upper body weight as well as muscular strength to achieve a harder draw. This aspect is still, however, relevant to some women.

5. Teaching of Technique

Without doubt, the emphasis upon training which dominated the 1980s has resulted in less attention being paid to technique by coaches. The standard of precision and bladework, even of the GDR crews, is not as high now as it used to be. This is true in many nations, and perhaps it is time that coaches paid more attention to the coaching of efficient technique.

2.0 Basic Principles

2.1 Body and Boat Principles

Compression vs. Reach (Orthodox) Technique

A. The advantages of full leg compression:

- Use full range of powerful leg muscles.
- Use them in the horizontal plane.
- Exploit the "fast contracting" - fast-twitch muscle fibres.
- Exploit the muscle-stretch reflex as the quadriceps muscles are pre-stretched round the knee joint.

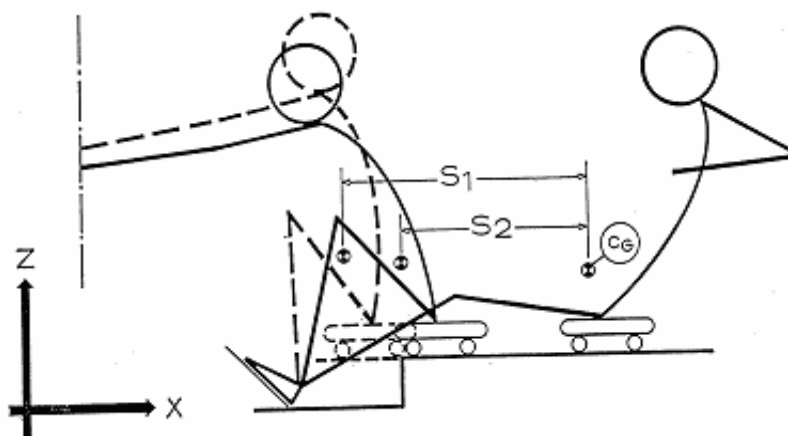

Fig. 2

B. The disadvantages:

The muscle fibres of the quadriceps group are also "fast fatiguing" fibres, and if used to maximum through the full range of movement in the early stages of the race, they fatigue earlier, which results in a large fade factor.

Exploitation of the muscle-stretch reflex in the leg extensor muscles contributes further to earlier fatigue.

The upright body position at the catch, in conjunction with the compressed legs, encourages athletes to "lock-on" at the catch with the back instead of the legs. The back muscles are slow contracting and cannot instigate the fast catch so essential to good technique.

In addition, the lack of necessary swing or hip pivot off the backstops encouraged crews to come forward on the recovery with no control - bodies even leaning backwards when crews were rigged with very high feet.

Flexible shoes, which allowed the heels to be lifted in order to achieve full leg compression, were introduced at this time.

There is little "lie-back" at the finish and this at least discourages pitching of the boat fore and aft.

C. In retrospect, this technique encouraged many bad faults to develop and, in GBR where this technique was used in its extreme form during the 1970s, we are still paying the price at club level where coaches who were taught to coach this technique now find it hard to change.

In its extreme, compressed technique encouraged short stroke arcs, no body swing on the recovery, little slide control coming forward, the catch taken with the back and extreme fatigue of the leg muscles building up very quickly.

A comparison of the drive of three popular international rowing styles.

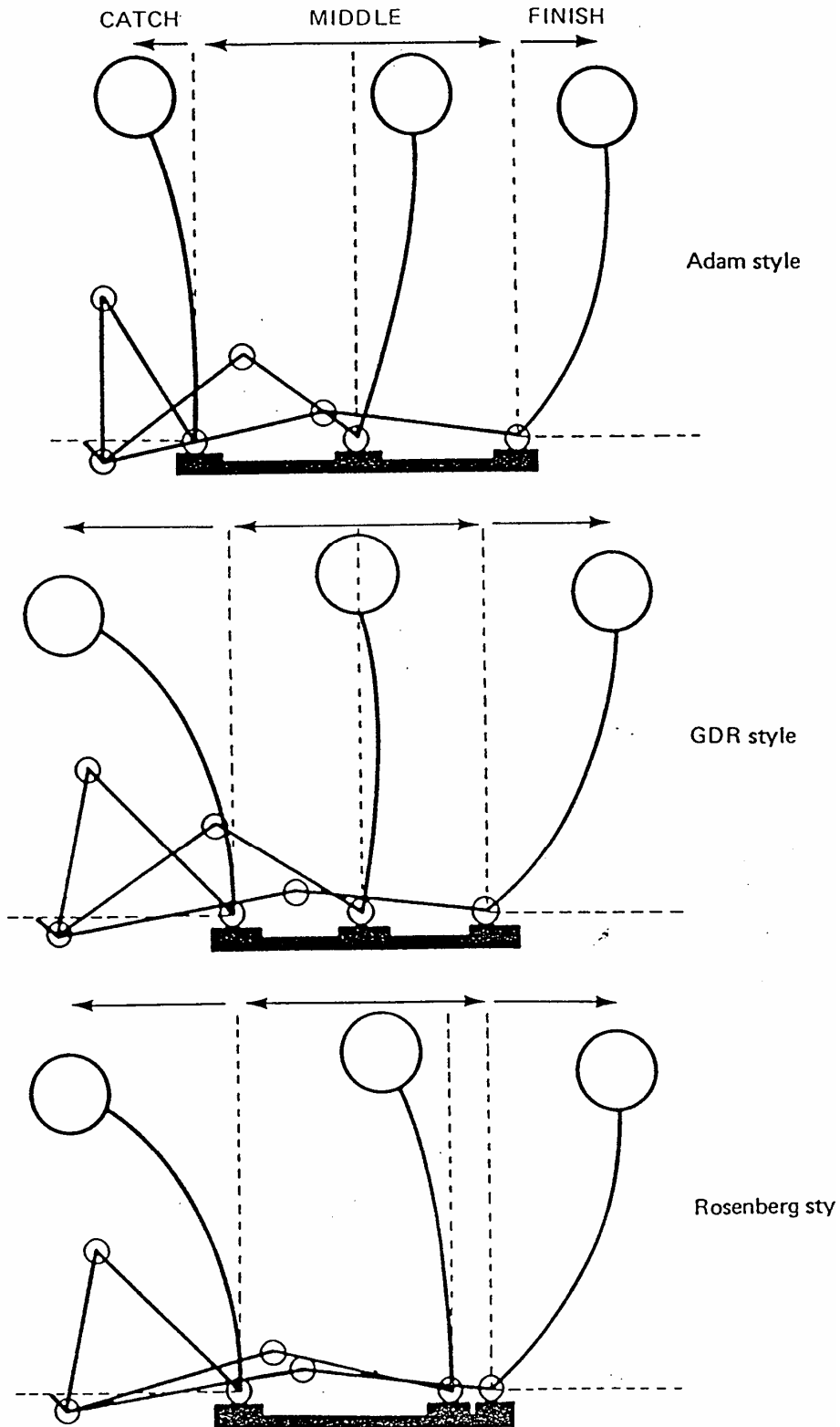

Fig. 3

In spite of this, many medals were won by nations using this technique in the early 1970s.

D. The Orthodox Technique

In the orthodox technique, as exemplified by the GDR on Figure 3, there is less leg compression and more upper body reach. The catch is clearly taken with the legs; the body position at the catch is achieved at the beginning of the recovery by pivoting from the hips off the backstops. The recovery is well controlled with the weight on the feet. Because the legs are not so compressed, there is less fatigue build-up in the leg muscles and the contribution of the back and arms is used sequentially - legs/back/arms. There is more "lie-back" at the finish than in the compressed technique with slight variations.

E. The Reach Technique

On Figure 3 this is referred to as the Rosenberg technique and is typical of USA crews through the 1970s until the present day. It is so named from the American coach, Allan Rosenberg, who coached the USA men's 8+ which won the gold medal at the 1974 World Championships in Lucerne.

Today, however, it is most associated with the Italian technique, which features less leg compression still, with a marked body reach position at the catch which is achieved by good coaching of hip pivot off the backstops to establish the body position for the catch before moving up the slide.

In addition, attention is paid to coaching full "reach" through the arms and shoulders in order to put the shoulder muscles, on full pre-stretch so that the "take-up" through the body, when the fast leg drive is applied to the oar handle, is reduced to a minimum. In this technique, the advantages of the muscle-stretch mechanism are used through the upper body where the muscle fibres are slow-twitch and thus slow fatiguing. Figure 4 shows the typical upper body reach of the Italian technique.

This technique also features a very strong leg drive from a more open knee angle with the body compressed hard against the thighs with full body reach. It should be emphasised that the body at the catch is "reaching" horizontal through the shoulders and not "overswinging" from the hips at the catch whereby the body would collapse and the catch would become more an inefficient upward lift than an efficient horizontal leg drive. Some would say the Italians "shoot their slides" but the important guideline is to compare the speed of acceleration of the oar handle with the speed of the slide.

This technique exploits a strong leg drive to achieve a force peak in the first third of the stroke which is what is ideally required, as we shall discuss later. Finally, there is slightly more "lie-back" at the finish than in the GDR technique.

In summary, most current variations of technique fall within the range of the "orthodox" technique (GDR) and "reach" technique used by the Italians. Relatively speaking, however, this represents a small range of variation compared to the extremes prevalent during the 1970s.

Women's technique also falls within this range.

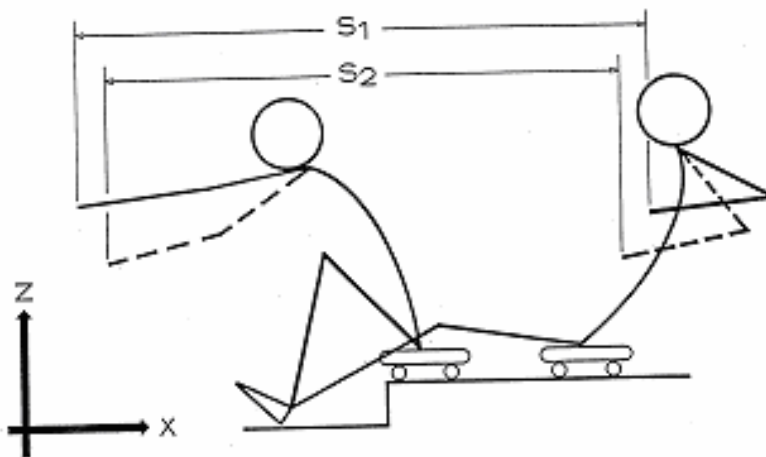

2. Higher Riggers - (Figure 5)

By higher riggers I am actually referring to the height of the "sill" of the swivel above the seat, and this also relates to the heights of the "sill" above the water.

In my opinion, the development towards higher riggers, especially in sculling, offers improved efficiency for a number of reasons:

i. As can be seen from Figure 5, it is possible to achieve a longer stroke because the length of reach of the arms is increased when the arms are more horizontal and assume the same height level as the shoulders.

Equally, the same applies to the length of draw at the finish. Since the body is some 25 degrees past the vertical at the finish and in a slight "C" shape, it is possible to draw longer at a higher level.

ii. With the arms more on the same plane as the shoulders, the contribution of the shoulders and upper body to the first third of the stroke is clearly increased. In addition, the body is in a "stronger" position and, equally as important, the power application is more in the horizontal plane.

iii. The disadvantages, however, are that whilst the finishing draw may be longer, it is also weaker since it is more difficult to achieve a strong arm draw and a "well covered" finish with higher riggers. This applies more to shorter athletes who do not, therefore, sit "tall" in the boat - (some women).

However, in my view, the positive benefits of increased length at the catch and increased power efficiency in the first and second third of the stroke far outweigh this disadvantage. A second disadvantage is that there is less stability and balance control and thus, heights should be increased only gradually as the confidence and proficiency of the athlete increase. High riggers also encourage "dropped" wrists on the recovery in sculling. This applies more to those with weaker wrists (some women) but this problem can be "coached-out" in conjunction with wrist strengthening exercises.

Dropped wrists on the recovery leads to other faults, particularly tight shoulders and a collapsed upper body. In addition, it encourages scullers to reverse their hands on the recovery.

Finally, as with all developments, there are some who have taken this to an extreme, and I consider sculling heights of around 21 cm are too high and are well beyond the optimum for the best technical efficiency. Of course, specific heights must relate to the physique of the individual. I should also mention that in sweep rowing the advantages of higher riggers are less marked since, with two hands on one oar handle, the hands are roughly either side of the centre line of the boat at the orthogonal point. Thus the inside hand - arm - and shoulder will be lower than the outside hand. This asymmetry in rowing means that riggers cannot be as high as in sculling. However, the trend has been in the same direction.

3. Sculling

i. Rigger Heights Level

Only if the swivel heights are set level can you achieve symmetry at the catch (entry) and at the finish (release).

If the riggers are set at different heights, scullers are often "out of time" with themselves. In other words, the left and right sculls do not enter and/or leave the water at the same time. You would be amazed how often this is the case. In addition, at the finish, it is more difficult to keep the higher scull "covered." At the extraction also, it is more difficult to extract and push away cleanly with the lower scull.

If the rigger heights are set at different levels, it only encourages scullers to scull with their hands one above the other during the "crossover" phases. If the hands are level at the catch and at the finish, yet above one another during the crossovers, then clearly the boat will "rock" during every stroke. This increases "drag" on the hull and also causes more instability in the boat.

ii. Hands Leading/Following

The debate continues as to whether or not the hands, during the "crossover" should be "above and below" or "leading and following." In GBR we have standardised "leading and following" with the left-hand leading at all times. This is also standardised in FRA and BEL, and most nations (except GDR) have standardised the left-hand lead/on top.

Before we standardised, I observed many thousands of scullers taking part in long distance races in the 1970s. I recorded 70% using the left-hand lead. On this basis, therefore, we standardised this in 1974. In addition, we know that technically the lower hand has a more difficult task because it is trapped under the upper hand. With most people being right-handed, therefore, it is logical to give the harder task to the more dextrous hand. If everyone is taught the same way, there is no problem and, of course, standardisation is essential for crew sculling.

In order to be efficient at the "crossover" during the propulsive phase, the asymmetry can be achieved either by a slight twist in the body and by advancing the right shoulder earlier, or by keeping the body symmetrical and bending the right arm earlier. The best technique uses a combination of these.

Equally, on the recovery, it is essential that the left hand lead after the extraction. If the wrists are dropped on the recovery, then usually the hands become reversed, and this is known in GBR as "knitting." We are assuming the "left-hand lead" technique is such that the right hand comes through first on the draw and the left hand leads away first on the recovery. Thus the hands remain in the same relationship throughout. However, dropped wrists cause the right hand to lead away first on the recovery whilst it is still the underneath hand. In this case, it is very difficult to control the balance on the recovery. Since this aspect of sculling technique is universally taught badly or not taught at all, I will describe the coaching sequence in depth.

At the catch the body and hands should be symmetric. As the "crossover" phase approaches, the RIGHT hand should draw a little earlier to come through first. During the draw phase, balance is entirely with the RIGHT hand and, therefore, the right hand should draw up at the finish to ensure that the boat does not drop down on the right hand side.

At the extraction, the hands should be level but immediately after the extraction the left hand should be coached to lead away faster so that during the recovery "crossover" phase the left hand is leading.

During the recovery, the balance of the boat is entirely controlled by the left hand, which should push down to stop the boat dropping towards the right hand side again. The key coaching points are:

During the propulsive phase:

RIGHT hand draw in first
RIGHT hand draw up during the draw

During the recovery phase:

LEFT hand lead away first
LEFT hand bear down to control balance

On the draw:

RIGHT hand
RIGHT elbow *FIRST*
RIGHT shoulder

On the recovery:

LEFT hand
LEFT elbow *FIRST*
LEFT shoulder

The best exercise to get the hands "right" during the propulsive phase is to try to get the sculler to draw through the crossover so that the right knuckles touch the underneath of the left wrist, i.e., where your watchstrap would be.

This is done only as an exercise and as such, the sculler must "feel" the right knuckles touch the left wrist on every stroke.

During the recovery phase, the fingers of the LEFT hand should be uncurled from the scull handles and straightened. If this is done with dropped wrists, you will lose the scull!!! You, therefore, HAVE to flatten the wrist first so that the scull

handle is balanced under the bridge of the fingers only. The sequence is to flatten the fingers of the left hand only on the grip as normal on the propulsive phase.

It is a natural body phenomenon that if you extend one joint of a limb the other joints in the same limb will also extend. The extension of the fingers, therefore, naturally develops into an extension of the wrist, the elbow and the shoulder. If this is done on the left side only, then a left-hand lead on the recovery will be achieved.

Equally, if dropped wrists on the recovery is a problem, then the exercise can be done with the fingers of BOTH hands being extended during the recovery phase.

Two months of coaching attention to the hands using the coaching points and exercises I have demonstrated, should establish good hand technique at the "crossover" phases, as well as better balance control on the recovery.

iii. Feathering

It seems that feathering the blade on the recovery has gone out of fashion! Notably the Italians hold their blades at a 45 degree angle to the water. The rationale for this is that if the blade is feathered "flat" and happens to touch the water on the recovery, it could get "caught in" on the forward edge and this would cause a "shipwreck." However, if the blade touches the water whilst feathered at 45 degrees it would simply "scuff" the water. Whilst this argument is valid, much more wind resistance is created if the blade is feathered at 45 degrees. In strong winds it is also much harder to control the blades if held at 45 degrees. Finally, to do so means that the scull (or oar) handles have to be gripped in order to be held at a 45 degree angle feather, whereas if they were allowed to rest flat on the sill of the swivel, which still gives 4 degrees from the horizontal (6 degrees with some swivels), the hands can be relaxed on the recovery. Gripping causes a build-up of tension in the forearms which is not to be encouraged.

I recommend feathering the blades flat (4 degrees) on the recovery and do not advocate the current trend in most nations. This applies to rowing equally as to sculling and this is an aspect of efficient technique which women particularly can benefit from at no extra cost.

iv. Body Sequence

We have already discussed the biomechanics of the use of the legs and back in relation to developments in technique in general. I would like to emphasise, however, that the essential difference between rowing and sculling is that the upper body is used a little earlier during the propulsive phase [in sculling]. This is especially required in single sculling since the single is the slowest boat and requires more upper body strength.

b. Whilst the legs initiate the catch and the "drive" phase, the co-ordination of the upper body begins earlier in order to make more use of the back and shoulders in the second phase of the stroke.

c. In addition, the shoulders are used much more than in rowing with the sequence being: legs - back - SHOULDERS - arms, as opposed to legs - back - arms. This difference needs to be brought out in coaching, especially with athletes who have learned to row before they scull.

v. Hip Pivot

In my opinion, the fundamental feature of rowing and sculling technique is the hip pivot as the hands lead away on the recovery.

As a coach, if you can teach this to your athletes, the rest is easy.

It is hard to teach because of the inter-relationship of the quadriceps muscles (knee extensors/hip flexors) and the hamstring muscles (knee flexors/hip extensors). Since both muscle groups work over two joints (knee and hip) with opposing actions, they must be considered together.

The length of the hamstrings are important in respect of the hip pivot at the beginning of the recovery since the knees are held down, the hamstrings are stretched and as you pivot over, the hamstrings are further stretched round the outside of the hip joint. This is why, when you try to touch your toes, you are inclined to bend your knees.

Due to less and less physical education in schools, plus an increasing lack of general exercise caused by the development of the phenomenon known as "the car," children nowadays are far less flexible than before the last world war. Thus the hamstrings particularly are shorter. In sculling and rowing, short hamstrings make it difficult to achieve a good hip pivot off the backstop. Hamstring flexibility should be trained out of the boat by regular flexibility training. It is of major importance in our sport.

I use the term hip pivot rather than body swing off the backstop because it is important to coach the movement from the hips and not achieve it simply by flexing the back. In this way, the body angle for the catch can be established off the backstops without the back "collapsing" on the way forward.

This is actually the hardest and most fundamental aspect of rowing and sculling, and a great deal of time should be spent coaching the athlete to master it. Hip pivot is essential to the achievement of a good recovery sequence of hands - body - slide. Time is needed and the emphasis should be: hands - BODY - slide.

vi. The Recovery

The way to achieve time and control on the recovery is to coach for EVEN speed on the slide. A good focus of attention to achieve this is to coach the athlete(s) to try to match the speed of the wheels on the slide to the speed of the boat. When equilibrium is achieved between these two speeds, then you get perfect harmony and the benefit is both relaxation of the body and the best "run" out of the boat during the recovery phase.

Few coaches relate to the "feel" of the "run" of the boat or the speed of the wheels on the slide (wheels is the key word here) and women particularly respond to attentional focus through the medium of "touch" and "feel."

vii. The Catch

I am not a believer in "bell notes" at the catch or indeed a "hit" catch. The best way to achieve an efficient "lock-on" to the water without bouncing the boat backwards,

or destroying the run, is to pick up the catch rather like a drive stroke in tennis. In tennis you would never coach someone to hit AT the ball, but rather to drive through it. In the same way, the catch should be almost a squeeze from full stretch. If all the muscles of the arms, shoulders and upper body are on full pre-stretch before the catch, then as the legs drive off the stretcher there will be instantaneous transfer to the blade in the water. Rather like a bow and arrow, the arrow is released when the bow is fully stretched. Scullers and crews who pick up the catch from full reach, and with a large arc forward, can achieve this "driving through" effect rather than just exploding off the stretcher and hitting the catch in an uncoordinated manner which "checks" the boat speed and fatigues the leg muscles sooner.

I consider that efficient technical application of the catch is of particular importance to women or those who are less strong. A longer arc forward, combined with a fast "pre-stretched" catch, can achieve maximum benefit from the first part of the stroke with minimum build-up of lactate.

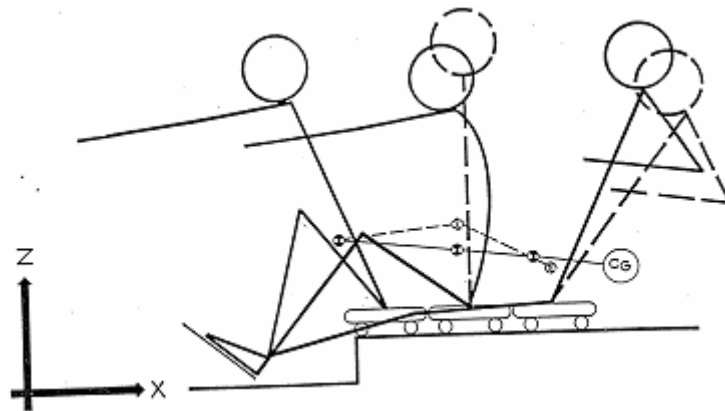

4. Horizontal Movement of the Centre of Gravity (CG) - (Figures 6-7)

To return now to the other basic biomechanical principles related to the boat and the body, it is important to reduce the range of horizontal movement of the CG as much as possible.

The figure shows that when using the compressed (Adam) technique the CG moves through a greater range at the catch. In addition, the longer the range of movement, the more difficult it is to control the velocity of movement of the body within the boat. Clearly, movement towards the bow is required in order for the legs to initiate and carry through the drive phase and the need to drive down fast to accelerate the oar handle and thus the boat. However, on the recovery, the velocity of movement up the slide can be controlled as mentioned earlier. In order to "flatten" the speed fluctuation curve (Figure 7) on the recovery phase, it is essential to achieve a "slow" and "even" speed on the slide. The flatter the curve, the less resistance there will be on the hull since resistance increases by the square of the speed such that boat speed acceleration should be kept to a minimum.

These mechanical principles underline the importance of coaching slide control on the recovery as described earlier.

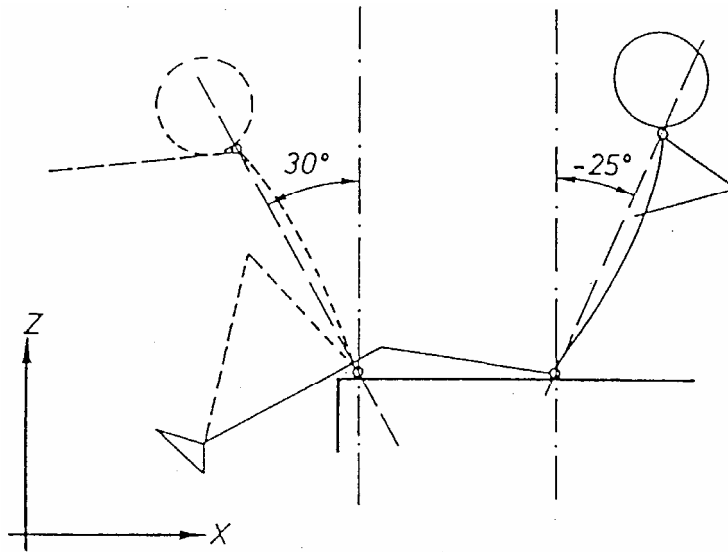

5. Vertical Movement of the Centre of Gravity (CG) - (Figure 8)

Movement of the CG in the vertical plane causes the boat to "pitch" fore and aft and this also increases resistance on the hull and decreases boat speed. As can be seen from Figure 8, excessive lie-back at the finish lowers the CG. Peter-Michael Kolbe who has very little lie-back at the finish, and who also displays little body reach forward has one of the lowest vertical movements of CG recorded. This can partly be explained by Figure 9 which shows the range of body swing at the catch and the finish of the singles finalists in the 1981 World Championship in Munich. However, it should be pointed out that they were using sliding rigger boats. The figure does, however, demonstrate the point.

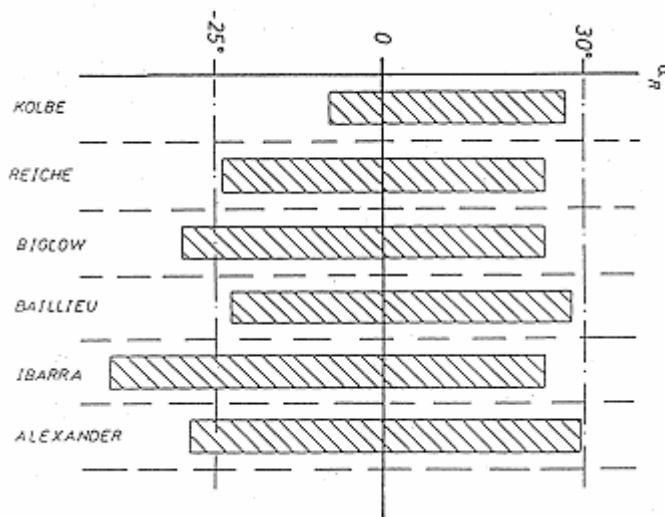

Fig. 9

Women are, in general, markedly less strong than men in the upper body and thus tend to lie back further at the finish in order to use upper body weight behind the draw to supplement lack of upper body strength.

It is in this respect, therefore, that coaches of women (if they are weak in the upper body) must compromise between the disadvantages of the lie-back in respect of increased power application to the blades.

In general, the need for "brute force" on the draw has reduced in favour of more endurance since the distance for women has been extended to 2000 m. I would not advocate that technique for all women need to exaggerate the lie-back at the finish, but clearly it may be beneficial for some. Coaches should use their own experience and intuition in this respect after consideration of the individual athletes being coached.

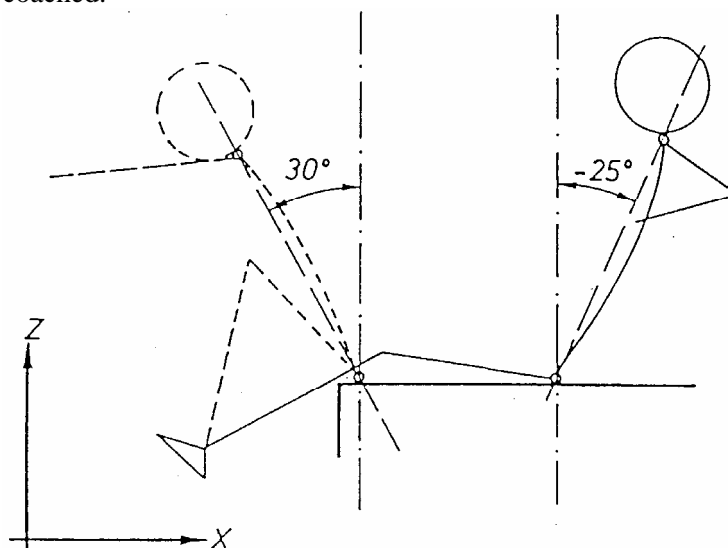

Fig. 10

Figure 10 shows the average body angles at the catch and the finish in sculling as:

+30 degree - catch
-25 degree - finish

In rowing, in general, there is more body swing at the catch and less at the finish giving probable angles of:

+35 degree - catch
-20 degree - finish

However, I am wary of quoting such averages since so much depends on back flexibility, hip flexibility and limb lengths. Again, coaches should evaluate the individual/crew and coach the most efficient body technique achievable, bearing in mind the limits of the various principles.

2.2 Oar Principles - (Figures 11-16)

During the 1970s and 1980s rigger spreads have changed. In the 1970s arcs became smaller (larger rigger spreads). The rationale for this was that, through the stroke arc, the components of propulsive force reduced either side of the orthogonal (Figure 11). Maximum efficiency was 20° either side of the orthogonal whilst at 50° to 60° either side the loss of efficiency was nearly 50% of that at the orthogonal point.

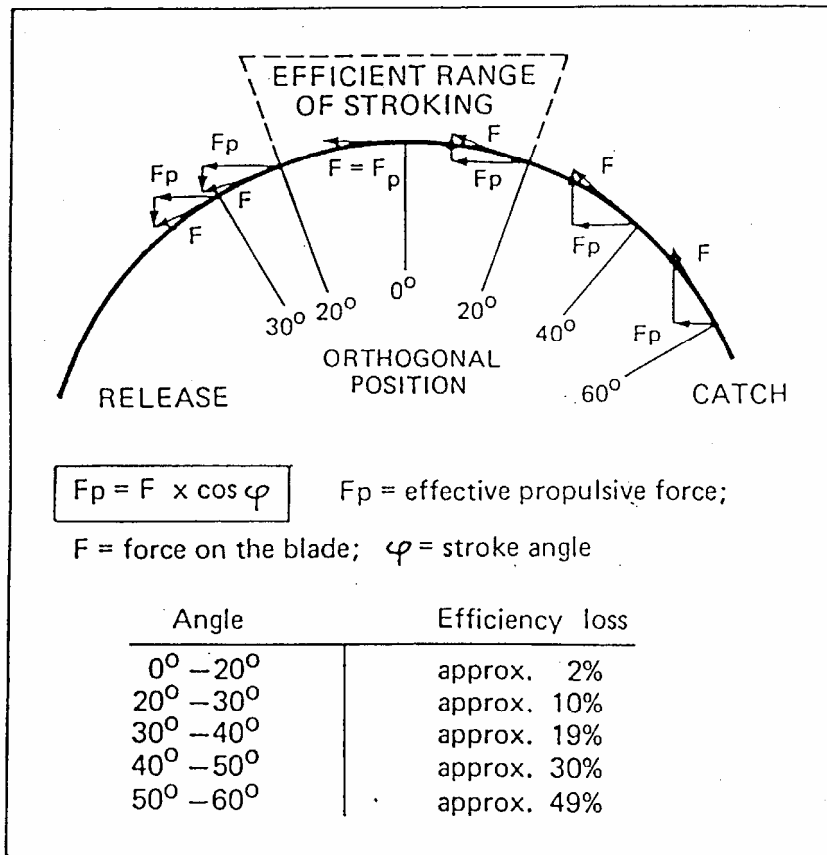

Fig. 11

In order, therefore, to achieve a long stroke (distance boat moved), whilst using only a shallow arc, rigger spreads were increased and then longer oars were introduced (see Figure 12).

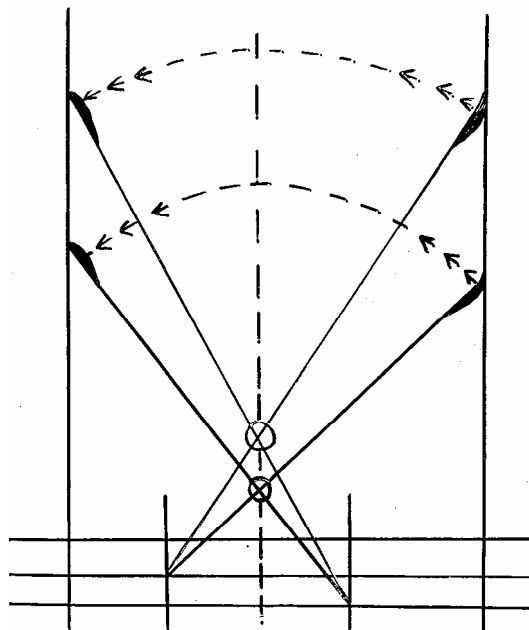

Fig. 12

In order to achieve the best results from larger spreads with longer oars/sculls, the rower needs to be very strong and very explosive because the shallower the angle of the pickup at the catch, the faster you have to lock-on to the water. This explosive technique with a smaller stroke arc was also a feature of crews who exaggerated the compressed Adam technique. The necessity to "hit" the catch fast led to early fatigue of the leg muscles and also to "checking" of the run of the boat at the catch.

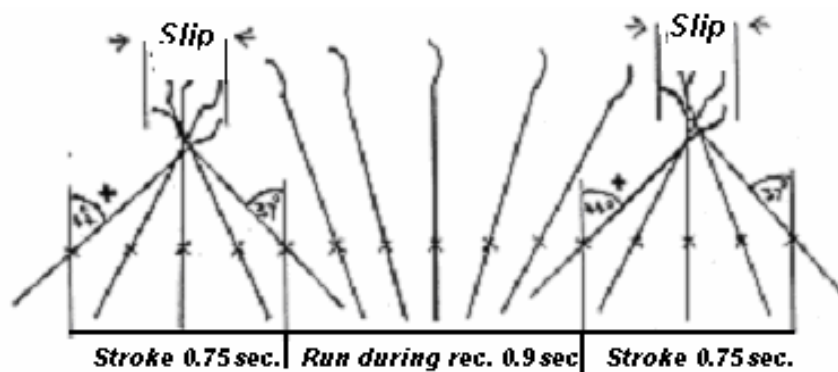

Fig. 13

Figure 13 shows the real movement of the blade in relation to the boat. Considered in this way the former argument in respect of the efficiency of the arc angles, is less strong. The boat is moved past the blade rather than the blade past the boat.

Finally, if we imagine that in this figure (13), the boat is also moving forward relative to the water, then this further undermines the arc angles argument.

We must remember that:

- The boat is moving relative to the water.
- The blades are moving relative to the boat.
- Also the athlete's body is moving in relation to the boat.

It is because it is difficult, using figures, to demonstrate the actual mechanics of the boat and the blade relative to the water that the arc angles rationale has been misinterpreted for so long. Now we have video and can also record arc angles and blade force, so we can understand the principles more clearly.

The best way to appreciate the real movement of the blade in relation to the boat and to the water is to analyse video taken from directly above a crew - preferably from a helicopter moving at the same speed.

From above you can see the effect of hydrodynamic lift on the blade at the catch, and the "slip" round the neck of the blade as the blade tip moves away from the boat laterally before the orthogonal and then moves back towards the boat after the orthogonal. (See Figures 13-16)

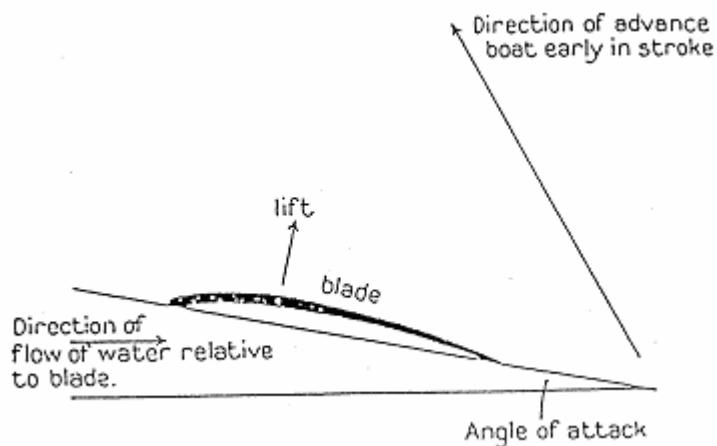

Fig. 14

It is interesting to note that Figure 15 was copied from a book entitled *The Way of a Man With a Blade*, which was written in 1957 by the famous British coach "Jumbo" Edwards. So the concept of hydrodynamic lift is not new. However, consideration of its relevance to boat propulsion has been given more consideration in recent years.

To appreciate the effect you should remember that as the blade enters the water at the catch, the boat is moving forward such that the blade actually pierces the water end-on, i.e., the blade is actually pushed into the water tip first by the forward movement of the boat. The greater the arc angle at the catch, the more this is the case. Thus water flows up the blade towards the shaft (Figure 16).

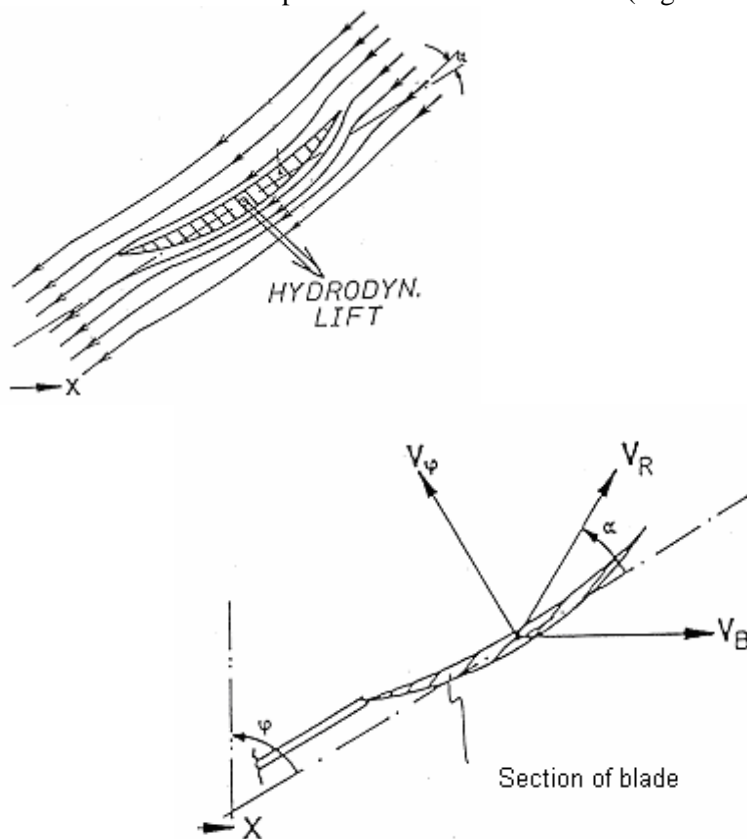

Fig. 15-16

Because of the hydrodynamic shape of the blade profile presented to the water, thrust is produced at 90 degrees to the blade.

This is the same principle by which an aircraft takes off. The aeroplane accelerates along the runway and because of the aerodynamic shape of the wings, there is vertical thrust which, above certain ground speeds, causes enough thrust to lift the aeroplane off the ground.

Bearing in mind the effect of both hydrodynamic lift and the fact that the boat is levered past the blade, it is clear that larger arcs forward are not a disadvantage as formerly suggested.

Finally, we should remember that there is a limit to the explosive power of the human being, especially for 5-1/2 minutes or more of effort. Also that a longer stroke with a smoother, wider force:time-curve profile will enable an athlete to propel a boat faster for a longer period of time than a shorter stroke with a higher force:time-curve peak.

The latter requires more explosive power from the athletes, brings on lactate fatigue faster, and causes greater boat speed fluctuations.

Thus, during the 1980s, stroke arcs have increased again, particularly in sculling, and rigger spreads have reduced. The longer oars are, of course, still used by the stronger and taller athletes, but those who are weaker and/or shorter are best advised to use shorter oars/sculls with a narrower spread in order to achieve a larger arc with a manageable work ratio.

Observations of current world class crews confirm the increased efficiency of larger arcs and, as I suggested earlier, length of stroke is the most important principle of boat propulsion.

Women particularly, should therefore, seek to establish a long stroke both by achieving maximum upper body reach at the catch, and by ensuring that the arc size is the first consideration when deciding what spread to use.

Many women are using spreads which are too wide, simply because they are using oars or sculls which are too long. The result is a short stroke, an impact orientated catch, and too much inboard overlap, which has the effect of further shortening the stroke. More on rigging later.

2.3 Force:Time-Curves - (Figures 17-21)

The final consideration of basic principles relates to the force:time-curve (FT) profiles. These vary from individual to individual. They vary with the same individual depending on the rate of striking, the spread of the boat and, therefore, the type of boat as well.

I only have time to consider the fundamental aspects of FT curves as they relate to technique in general rather than as they relate to individuals.

Because we cannot pull on the oar handle unless it is in front of us, and because the leg drive provides the main source of power applied to the handle, it is clear that peak power cannot be achieved at the orthogonal point of the arc. Figure 17 shows a typical FT curve profile and you can see that the peak force occurs well before the

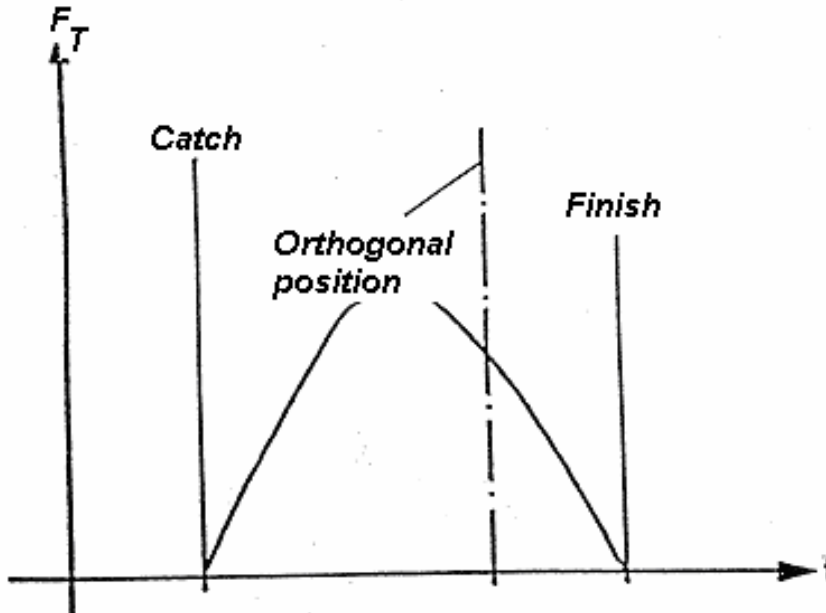

Fig. 17

Orthogonal (intermittent line). From Figure 18 we can see that the force peak is in the middle third of the arc but that two thirds of the arc occurs before the Orthogonal. Figure 19 shows an FT curve in relation to the blade and body positions.

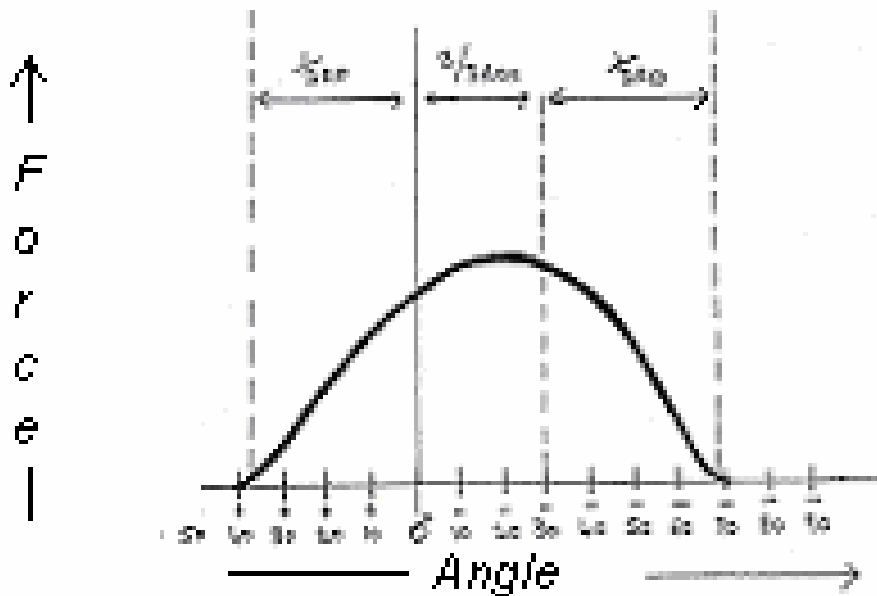

Fig. 18

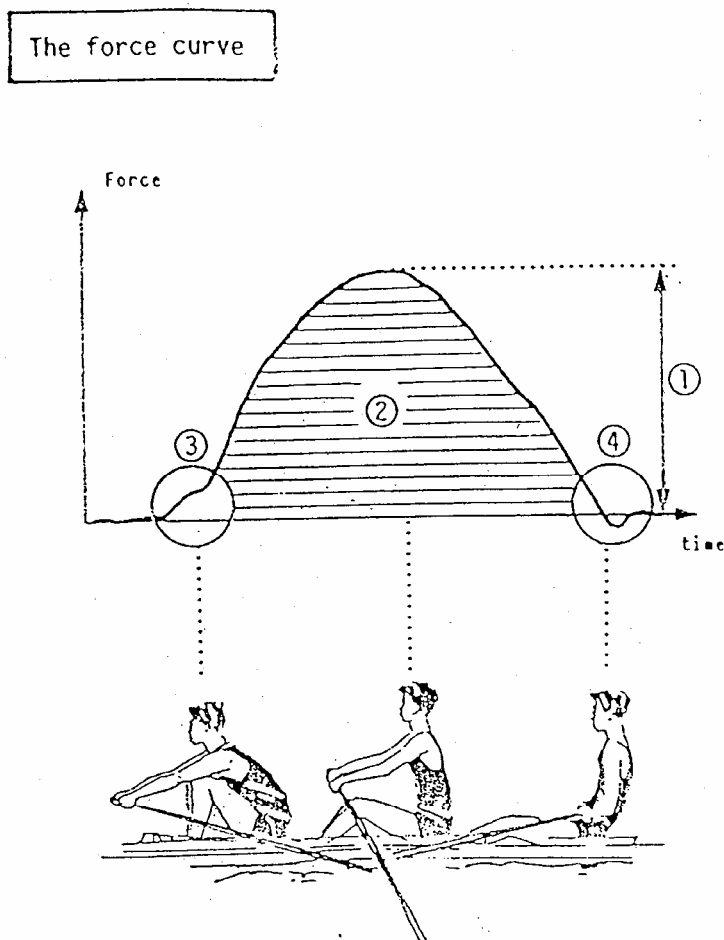

Fig. 19

Figure 20 shows the individual FT curves for the legs (knee angle), back (hip angle) and arms (elbow angle), which better explains why the FT curve peak, is 30-40 degrees before the orthogonal point.

Velocity of opening of body angles

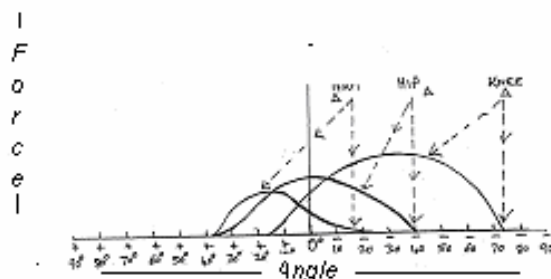

Fig. 20

If presented with an individual FT curve, we know that further improvement in power output would be indicated by a larger area of impulse under the curve. If we assume that with improved strength, fitness and technique we could increase the area under the curve, how should we do it? Should we increase the peak force or should we broaden the current shape?

Without doubt, I would recommend that the current shape should be broadened and maintained for longer.

In respect of larger stroke arcs, I should emphasise that they have not increased at the finish, and about +37 behind the orthogonal (see Figure 18) is optimal. Since the boat is moving fast through the water, any arc larger than about 40 degrees results in the boat "towing" the blade out of the inside of the puddle such that the blade acts like an inefficient "flipper" being dragged along behind. Clearly this acts as a brake on the boat speed.

In general, at the catch scullers such as Karpinnen can reach -70 degrees from the orthogonal, whereas -60 degrees is the average in sculling. In rowing it is a little less and women seem to be some 10 degrees shorter at the catch than men. This, however, could be changed by rigging.

Consideration of length of stroke, and the method of power applications at the catch, in the light of FT curves further underlines the importance of a longer stroke with larger arc angles at the catch which gives "time" for a smooth, sustained power output over a longer time. Again, this emphasis is more applicable to weaker people who do not have so much latent explosive power. Even with the strongest men, a technique emphasising high peak force with a shorter stroke burns you out very quickly. In addition, hydrodynamically it is not the most efficient way to move a boat.

The data on FT curves, which has accumulated during the 1980s, again endorses the greater efficiency of a long stroke giving time to develop a smooth "full" FT curve. Both the mechanical, biomechanical and physiological data support the fundamental importance of a long stroke.

The table in Figure 21 first published at the FISA Coaches Conference in Athens in January 1991 by Dr. Schwanitz and Dr. Roth (biomechanist and physiologist from the GDR) presents an overview of the mechanical, biomechanical and physiological basis of rowing technique. Analysis of this table could be the basis of a whole weekend of discussion, so I include it here only for your future personal analysis.

2.4 Rigging

It is my contention that many women at both club and international level (especially lightweights) are using inefficient rigs in respect of the following:

- Too large spreads causing too short stroke arcs
- Too long oars/sculls
- Too long oars/sculls INBOARD giving too much overlap

We have already discussed the advantages of a large arc and therefore I will only add some comments on overlap here.

When choosing a rig the priority order is as follows:

1. Decide the spread, which will allow you to scull/row the size of arc you require.

2. Decide the length of the oar/scull OUTBOARD that will give you an appropriate leverage from the size of your arc.
3. Decide the overall length of the oar/scull by adding the INBOARD length required to give you an overlap appropriate to your overall height and particularly your leg length.

i. Overlap

By this, I am referring to the amount by which the inboard overlaps the centre line of the boat at the orthogonal point.

Inboard length has little effect on gearing. It is the outboard length of the oar which is the major leverage factor. This is why we usually quote gearing as spread (minus 2 cm) in relation to outboard. 2 cm are subtracted from the spread (4 cm in sculling) to allow for the difference between the pin (fulcrum) and the inside edge of the swivel against which the oar/scull collar rests. Any length of inboard which overlaps the centre line of the boat, is primarily related to factors other than gearing.

In rowing average overlap is 32 cm. Too long inboard restricts arc length at the catch. Equally, too little causes a weak draw because the outside shoulder, forearm and hand cannot draw directly behind the handle since the end of the handle will swing inside the outside line of the body. This also encourages the outside hand to roll round the end of the handle - then the outside elbow to drop - then the outside shoulder to collapse - and finally the rower to lean out, or away from the rigger at the finish. This reduces further the power of the draw and may also cause balance problems.

Overlap is, therefore, an important dimension to consider and should not be too long or too short. In general, shorter athletes need less overlap.

In sculling also, too much overlap reduces the arc angle at the catch and severely reduces the length of the draw.

The average overlap in sculling is about 22 cm. (The amount by which both scull handles overlap each other.) In the faster moving boats, where more room is needed to extract cleanly and move the hands away quickly, overlap may be less than this. However, overlap is a very individual dimension depending very much on leg-strength.

Tall athletes with long legs need larger overlaps because they have the leg length to "uncross" the overlap as their legs straighten at the finish. Indeed, if they had too little overlap, they would be so far back from the scull handles at the finish that they would simply be pulling the scull handles inboard and the collar away from the swivel.

For shorter athletes, however, and this means many women, this is reversed. If you have shorter legs then you do not have the leg length to "uncross" the overlap at the finish. Many women that I observe sculling have barely 10 cm between their hands at the extraction because their inboard scull lengths are too long and they have too much overlap.

This means that the finish cannot be drawn hard and long, and the sculler's shoulders are "tight" and hunched because she cannot open-up and draw back the shoulders properly at the finish.

This situation occurs because shorter scullers follow the average guidelines for "overlap" and do not realise that overlap needs to be less than average for shorter athletes. Overlaps of 17-19 cm are more appropriate for shorter athletes.

I believe that if many shorter women checked their "set-ups" they would find that probably they would be better with 296 cm sculls instead of 298 cm, the latter being more appropriate for taller scullers on standard overlap.

ii. Women's Rigging Tables - 1988 Olympic Games and World Championships

My second comment in respect of women's rigging is that I believe that many women's crews and single scullers are using spreads, which are too large. This reduces the length of stroke arc and requires a very explosive technique not suited to weaker athletes.

Here are two examples of rig from the 1988 Olympic Games Women's Singles together with the heights and weights of the athletes concerned:

Table 4: Women's Rigging Tables - 1988 Olympic Games Single Sculls

	Height	Weight	Spread	Sculls	Outboard	Inboard	Overlap
A.	1.83 m (6'0")	80+ kg (13+ st or 175+ lbs)	158 cm	298 cm	210.5 cm	87.5 cm	21 cm
B.	1.75 m (5'8")	64 kg (10st or 141 lbs)	158 cm	296 cm	207cm	89 cm	24 cm

Before commenting further, I should point out that these tables cannot be guaranteed as correct and there could well have been misidentification of boat and/or sculls for each athlete. However, the figures are useful as an example.

Comments:

1. Athlete A is much taller than athlete B and yet they are on the same spread. With a much shorter reach, therefore, athlete B would have a much shorter stroke arc than athlete A.

2. Athlete B has a much shorter outboard no doubt to give her an easier gearing since she is a lightweight. However, with the same spread and sculls 2 cm shorter overall, she still has very long inboard dimensions because of the short outboards. This gives her an extremely large overlap of 24 cm which will further restrict her length of stroke both at the catch and at the finish. With shorter legs than athlete B the situation is even worse.

3. Does athlete B really need such a short outboard lever? I doubt it, but if she does, should she use even shorter sculls or a larger spread in order to solve the problem? I would not choose a larger spread.

4. Again, it is likely that these dimensions are not correct, but the rigging "set-up" of athlete B is typical of the problem I observe world-wide with the rigging of shorter women.

5. After the women's distance was increased to 2000 m in 1985, I expected a change in women's spreads which would reflect greater endurance efficiency over the longer distance and less orientation towards "brute power" rowing. In other words, I would have expected women to use narrower spreads than previously and thus to use shorter oars/sculls as well.

6. It is interesting that the women (and men) of the GDR have kept their spreads the same throughout the last twenty years with a few exceptions in the single scull to allow for individual extremes. They have remained narrower and we have all observed the very long efficient stroke arcs demonstrated by the GDR women.

7. The questions should be asked: "Is it simply natural conservatism which has kept women's rigging the same for 2000 m as it was for 1000 m?" There is, of course, always a reluctance to experiment, and we know that in our sport it is difficult to measure objectively the results of rigging changes, particularly in the short-term.

However, over the last couple of years, I have seen some signs of change in the direction I would expect. Perhaps the points I have raised today, in conjunction with my appraisal of technique, might stimulate all the coaches here to review their own views on technique and particularly to have a look afresh at the rigging implications for women.

3. Summary

1. Technique - General

- i. Women need better (more efficient) technique.
- ii. Coaches of women should not take technique for granted - teach well and teach methodically.

2. Technique - Key Points for Women

i. Long Stroke Arc

Achieved by:

- Body Technique - Reach through shoulders
- Rigging - Narrower spreads to give larger arcs

ii. Hip Pivot - Basis for teaching technique

iii. Shoulder Reach/Stretch - Essential for an efficient catch

iv. Leg Drive at Catch - Fundamental basis of propulsive phase

v. Lie-Back at Finish - May still be needed by some weaker and/or shorter women

vi. Feathering - If properly taught, it uses no extra energy, so why not feather flat?

vii. Sculling

- Left hand lead
- Hands leading and following
- Body co-ordination - legs - back - SHOULDERS - arms

3. Rigging

- i. Riggers Higher - Especially in sculling
- ii. Riggers Level - In sculling
- iii. Spreads - Are they too large giving a shorter arc?
- iv. Oars/Sculls - If spreads were narrower, oars/sculls should be shorter
- v. Overlap - Should be less for shorter athletes particularly in sculling

4. Recommendations for Women

Women should endeavour to row/scull larger stroke arcs for the following reasons.

A longer stroke:

- Is much more efficient mechanically and biomechanically.
- Requires a less "impact" orientated catch.
- Encourages a larger arc angle forward which makes it easier to pick-up the catch.
- Provides a longer time of stroke during which to develop power.
- Encourages a more even application of power.
- Creates less lactate build-up and, therefore, is less fatiguing throughout the race.
- Creates less boat speed fluctuation and, therefore, less drag on the hull.